

Side and End Mounting - Rectangular Tank

Tank Depth (mm)	Arm Length (mm)	
	"Bimetal"	"Euro"
610	338	310
584	325	298
559	312	286
533	299	275
508	287	263
483	274	252
457	261	240
432	249	228
406	236	216
381	223	205
356	---	193
330	---	181
305	---	170
279	---	158

Side and End Mounting - Cylindrical tank

Tank Depth (mm)	Arm Length (mm)	
	"Bimetal"	"Euro"
610	283	260
584	272	250
559	262	240
533	251	230
508	241	221
483	231	212
457	220	202
432	210	193
406	199	183
381	189	173
356	179	164
330	168	154
305	158	145
279	147	135
254	137	126
229	126	---
203	---	---

Wiring Diagrams

Earth Return

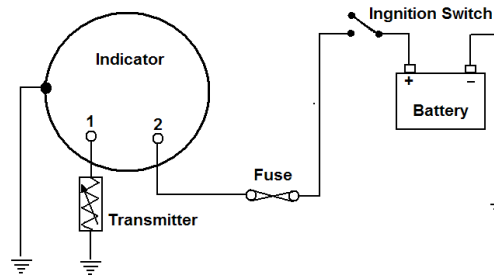

Insulated Return

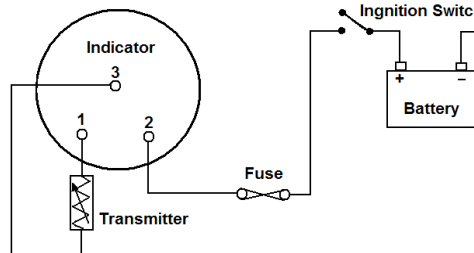

Notes

- Low level warning light facility only available on earth return transmitters ("W" terminal).
- "W" terminal on insulated return transmitters is return to battery negative.
- "T" terminal on both earth and insulated return transmitters is connection to indicator.

Caerbont Automotive Instruments Ltd.
Abercrave, Swansea, SA9 1SH.
Tel: 01639 732200 Fax: 01639 732201



Caerbont Automotive Instruments

'The original makers of SMITHS Instruments'

Fuel Contents Transmitters/Senders

Variable Length Type:

TB90 /KIT

For uniform section rectangular or circular tanks with 6 hole flange fixing.

Code	Description
TB9006/KIT	Top mounted, warning light "Bimetal" characteristic
TB9010/KIT	Top mounted, earth return "Euro" characteristic
TB9011/KIT	Top mounted, insulated return "Bimetal" characteristic
TB9012/KIT	Top mounted, insulated return "Euro" characteristic
TB9013/KIT	Side mounted, insulated return "Bimetal" characteristic
TB9014/KIT	Side mounted, insulated return "Euro" characteristic
TB9018/KIT	Side mounted, earth return "Euro" characteristic

General Fitting Instructions

- Measure internal depth/diameter of the fuel tank.
- Select arm length required against tank depth measured, from appropriate table.
- Assemble the wire arms and clips as shown in the diagram to give the specified arm length.
- Ensure that the float axis is parallel to the tank unit flange.
- Trim excess wire retaining maximum overlap to maintain rigidity.
- Solder at and around the two clips, guard against overheating.
- Fit the float to the end of the arm, either way round is acceptable.
- Coat both sides of gasket with sealant and assemble tank unit to tank flange.
- Secure firmly and evenly.

NOTE: Interpolation between max and min. listed values only is permissible; using the nearest listed value to that measured.

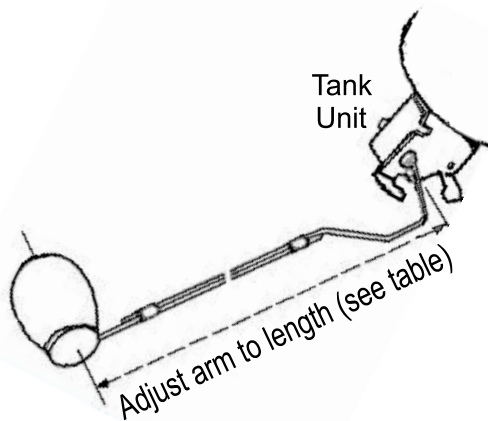

Wiring Connections

(For wiring diagrams see back cover)

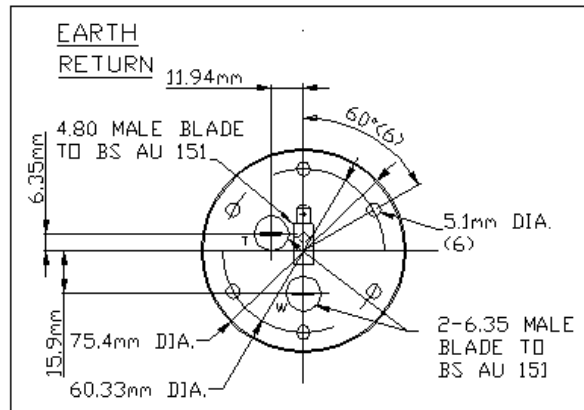
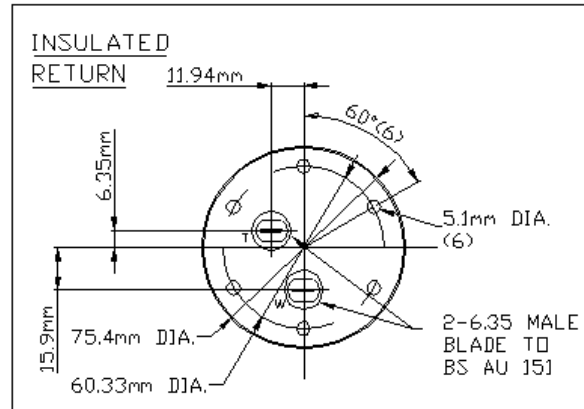

Top Mounting – Rectangular Tank

Tank Depth (mm)	Arm Length (mm)	
	"Bimetal"	"Euro"
610	542	494
584	517	471
559	492	449
533	466	425
508	442	403
483	417	380
457	391	357
432	367	334
406	341	311
381	316	288
356	292	266
330	266	243
305	241	220
279	216	197
254	191	174
229	165	152
203	141	128

Top Mounting – Cylindrical Tank

Tank Depth (mm)	Arm Length (mm)	
	"Bimetal"	"Euro"
610	542	494
584	517	471
559	492	449
533	466	425
508	442	403
483	417	380
457	391	357
432	367	334
406	341	311
381	316	288
356	292	266
330	266	243
305	241	220
279	216	197
254	191	174
229	165	152
203	141	128